

ELBA

Aqueous cleaning system with wash and rinse stages.



MAFAC
CREATIVE CLEANING



A new aqueous cleaning system for work cells.

The end of your search is in sight with an ELBA industrial parts cleaner. The ELBA meets the most diverse requirements in cleaning industrial parts with a water-based system which is flexible and reliable. Metal working companies producing turned parts, mechanical workshops or automobile component suppliers profit from the advantages which ELBA offers, as do electro-plating, hardening or lacquer shops. ELBA has the answers for demanding applications: whether as a central cleaning location or in individual production cells. ELBA is a compact, user-friendly and environmentally friendly solution with a high performance.

Special features include a dual wash tank system, integrated warm air drying, easy to use electronic control, digital text display. Simply enter and save your individual cleaning program without complicated codes and follow the wash cycle from the text display. A hinged loading door is standard on the ELBA. An alternative vertical sliding door is an available option, which can be combined with an automatic basket transfer system for fully automatic operation.



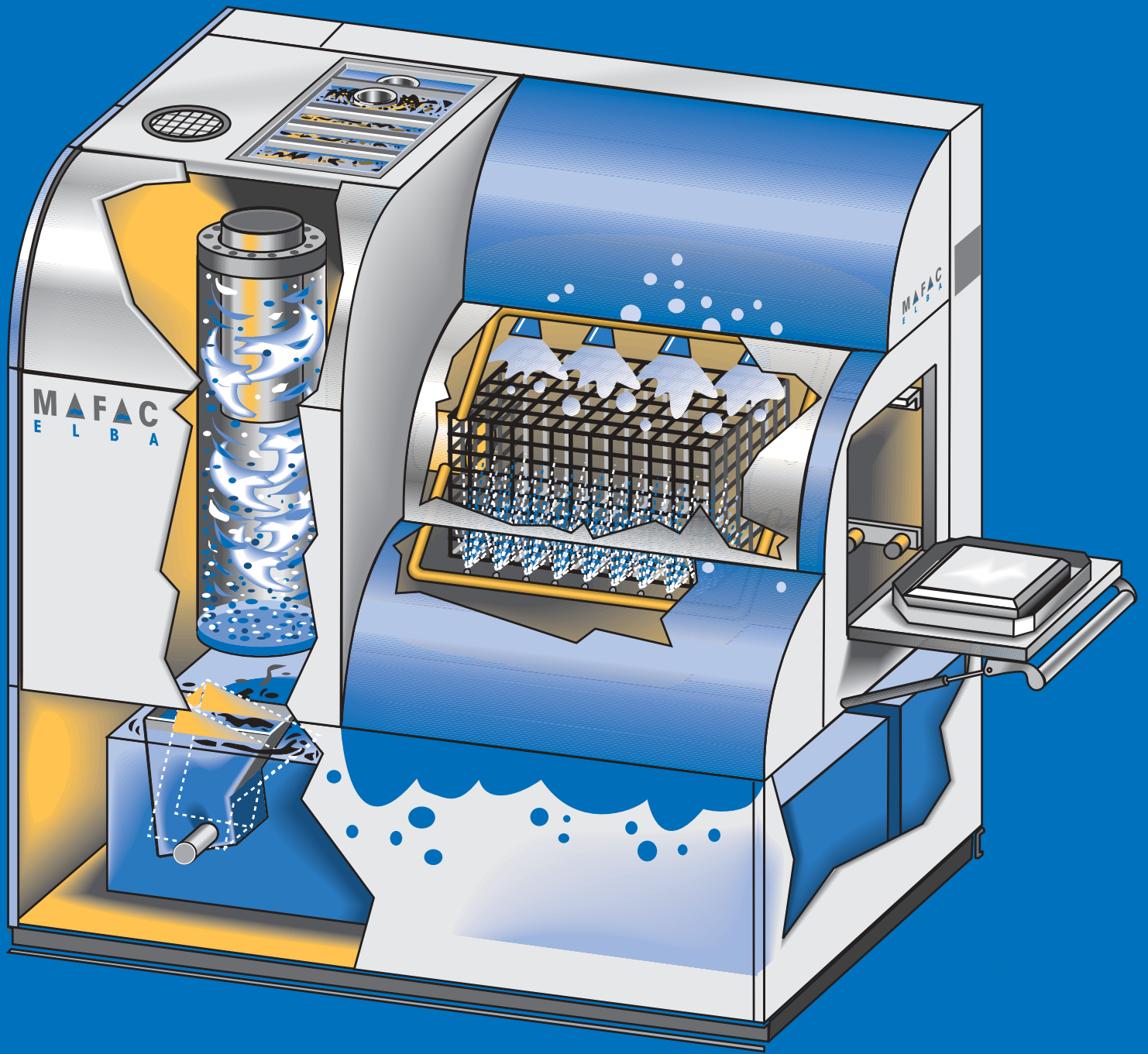

ELBA the eco-friendly answer to your industrial cleaning needs.

- Two solution tanks provide additional cleaning possibilities.
- Electronic control system with full text display.
- Integrated rotary heated compressed air drying system (option).
- Wash cycle visible via viewing port in the machine frame.
- Rotary spray system with counter rotation of wash load (patented).
- Filtration in wash and rinse mode.
- Mechanical ultra fine filtration in the wash and rinse process (optional).
- Advanced spray nozzle configuration, produces reliable cleaning results.
- Separate heating of the wash and rinse solutions.
- Cascade from rinse to wash solution.
- To order: Transfer system for automatic loading of the cleaning line.

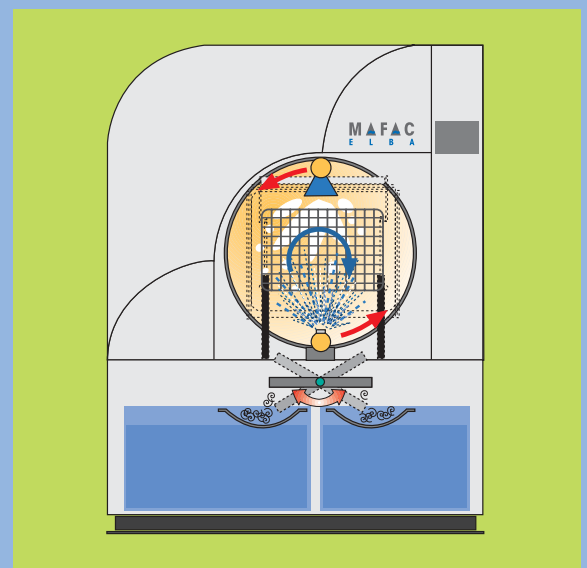
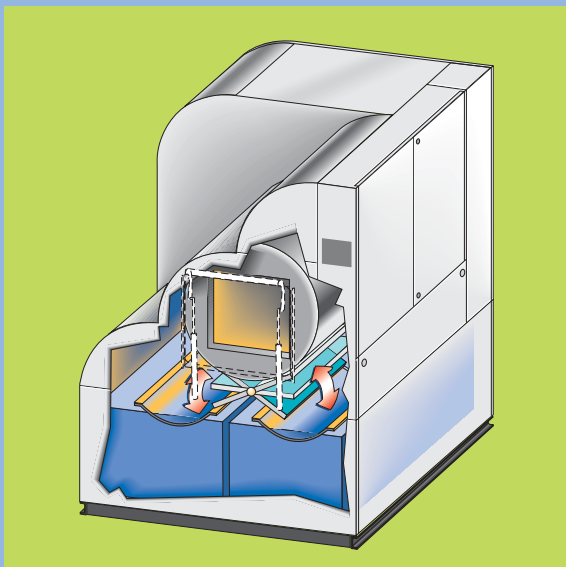

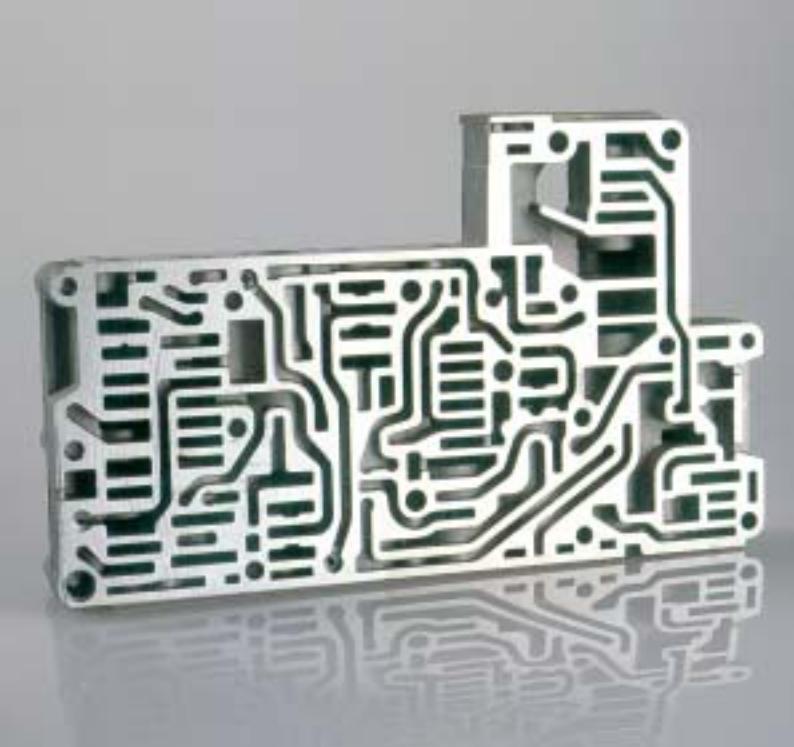

For demanding cleaning of industrial components.

With the integrated two stage system ELBA can handle the toughest cleaning tasks. Bulk material, individual components or batch cleaning of ferrous and non ferrous metals and plastics can be processed with the required cleaning chemistry. The two tanks provide process flexibility for varied demands, pre treatment and passivation processes can be easily handled by ELBA. Consult us about your particular cleaning requirements, we will be pleased to help.

Excellent customer service is just as much part of our standard program as the preparation of customer test cleaning at our premises. The service-friendly and competent MAFAAC team will be delighted to show you our convincing solutions.

Environment-friendly, economical and creative.

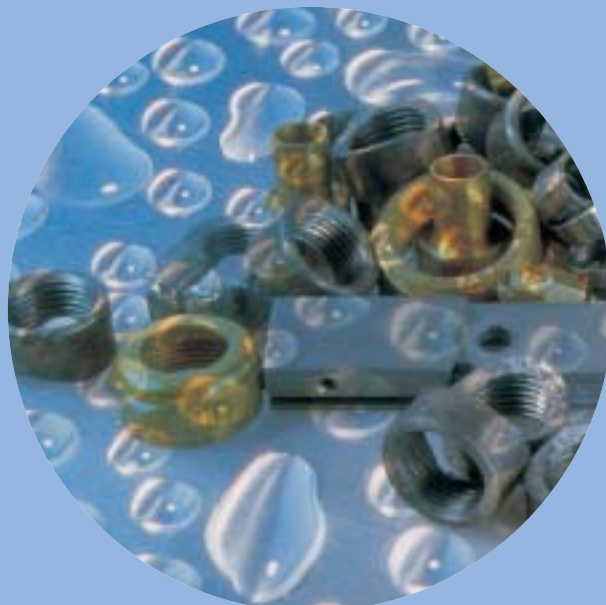

The ELBA in detail.

Technical data:

Cleaning System:			
Pump rating/pressure	Washing	kW/bar	4,0/3,5
	Rinsing	kW/bar	1,0/1,6
Volumetric flow	Washing	l/min.	385
	Rinsing	l/min.	210
Filling capacity	Washing	l	475
	Rinsing	l	300
Filtration	Washing, rough	µm	150
	fine (option)	µm	100
	Rinsing, rough	µm	150
	fine (option)	µm	50
Solution heating	Washing	kW/max. °C	13/75
	Rinsing	kW/max. °C	13/75
Heat-up time	(20-70°C)	h	approx. 2
Load capacity		kg	100
Extraction/condensation of water vapours:			
Mean volumetric flow of exhaust air-condensed		m³/h	600

Pulsed jet system (option):			
Volumetric flow of compressed air	l/min.	approx.	3200
At air pressure of	bar		6
Mean noise level	dB(A)	approx.	78
Connections:			
Electrics	V, Ph/Hz/kVA	400, 3/50/36	
Pneumatics	inch/bar	Rp 3/4, 5-8	
Waste water (cleaning/rinsing)	both inch Rp	1 1/2	
Exhaust air	mm	DN 120	
Dimensions:			
working chamber			
A/E/G (maximum)	mm	660/480/340	
Total space B/C/D/F	mm	1800/1830/855/1400	
Weight:			
Net	kg		950
Gross	kg		1000
Color:			
	RAL	7035/light grey	ELBA blue

Standard features:

- Front loading with hinged door and sliding tray
- Patented spray system wash load contra-rotation
- Spray cleaning and rinsing on one unit
- Suitable for basket up to 660 x 480 x 340 mm
- Filtration of washing and rinsing medium
- Solution heating system with temperature control
- Thermal insulation
- Vacuum extraction system with water vapour condenser
- Oil separator (by coalescence) with oil container and maximum level monitor
- Solution level control system with cascade from rinse to cleaning tank
- All wetted components of stainless steel and plastic
- Programmable user-friendly control system with full text display (MMC).

Component designation:

ELBA cleaning line for baskets of max. size (L) 660 x (W) 480 x (H) 340 mm _____ 69000000
 BW 66.48 loading carriage with oil sump _____ 69000008

Accessories and special features:

Pulsed jet drying system with heat exchanger for parts drying (compressed air has to be provided) _____ 6900 0002
 Heated turbo drying _____ 6900 0003
 Mechanical fine filtration of wash solution _____ 6900 0005
 Mechanical fine filtration of rinse solution _____ 6900 0004
 Demineralization unit for fresh water _____ 6900 0010
 Rocking basket motion with speed control _____ 6900 0006
 7 day timer including solution maintenance programme _____ 6900 0007
 Solution avacuation pump _____ 6010 0006
 Stainless steel solution spill tray _____ 6010 0007
 Automatic vertical sliding door instead of a hinged door _____ 6900 0023
 Interface for transfer system _____ 6900 0015
 Automatic transfer system (2 baskets) _____ 6000 0001

Standard baskets in stainless steel-1.4301 (dimensions: 600 x 400):

Standard basket 20/4, electrolytically polished, mesh width 20 mm, height 285 mm _____ 6420 0078
 Standard basket 10/4, electrolytically polished, mesh width 10 mm, height 285 mm _____ 6420 0076
 Standard basket 6/2, electrolytically polished, mesh width 6 mm, height 285 mm _____ 6420 0101
 Custom basket design _____ on request

Cover unit 20/4, electrolytically polished, mesh width 20 mm, adjustable height _____ 6420 0081
 Cover unit 10/4, electrolytically polished, mesh width 10 mm, adjustable height _____ 6420 0077
 Cover unit 6/2, electrolytically polished, mesh width 6 mm, adjustable height _____ 6420 0102

Dimensions:

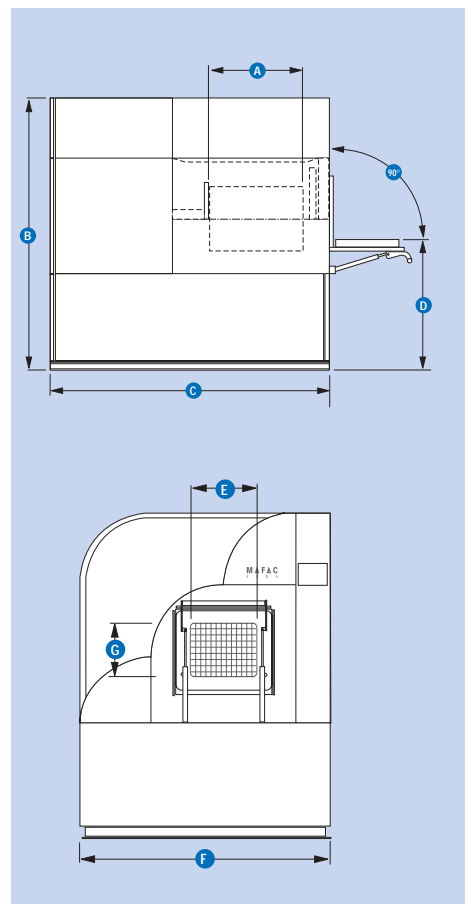

Your Sales Representative:

We will be pleased to send details of our complete line.



Ernst Schwarz GmbH & Co. KG
 Max-Eyth-Str. 2, D-72275 Alpirsbach
 Phone + 49 (0) 74 44/95 09-0
 Telefax + 49 (0) 74 44/95 09-28
 www.MAFAC.de
 E-Mail: info@mafacc.de

CREATIVE CLEANING